

Phono[®] Solar

Premium Plus Module

Mono/310-325W/Big Cell



More Power

Higher conversion efficiency, more power production per unit area



Lower System Cost

Higher conversion efficiency helps to save transportation-, installation- and BoS cost



Better Low-light Performance

Enhanced spectral response at longer wave length boosts low-light performance, which can produce more than 3% additional power compared with conventional module at system side

Bloomberg
NEW ENERGY FINANCE

Tier1

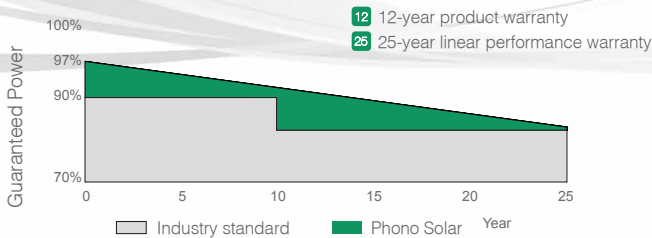
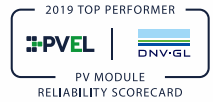

EN EN-20190704

SINOMACH | SUMEC
SUMEC GROUP CORPORATION

ELECTRICAL TYPICAL VALUES

Model	PS310M1-20/U PS310M1H-20/U	PS315M1-20/U PS315M1H-20/U	PS320M1-20/U PS320M1H-20/U	PS325M1-20/U PS325M1H-20/U
Type	PERC Monocrystalline 158.75mm x 158.75mm square, 6 x 10 pieces in series			
Rated Power (Pmpp)	310W	315W	320W	325W
Tolerance	0~+5w			
Rated Current (Impp)	9.54	9.64	9.75	9.86
Rated Voltage (Vmpp)	32.50	32.68	32.83	32.97
Short Circuit Current (Isc)	9.92	9.98	10.04	10.09
Open Circuit Voltage (Voc)	40.10	40.20	40.30	40.40
Module Efficiency (%)	18.61	18.91	19.21	19.51
NOCT (Nominal Operation Cell Temperature)	45±2°C			
Voltage Temperature Coefficient	-0.31%/°C			
Current Temperature Coefficient	+0.05%/°C			
Power Temperature Coefficient	-0.39%/°C			

MECHANICAL CHARACTERISTICS

Dimension (L x W x H)	Length: 1666mm (65.59 inch) Width: 1000mm (39.37 inch) Height: 35mm (1.38 inch)
Weight	18.5kg (40.78 lbs)
Front Glass	3.2mm toughened glass
Frame	Anodized aluminium alloy
Cable	4mm ² (IEC) , Length:900mm or Customized length
Junction Box	IP 68 rated

ABSOLUTE MAXIMUM RATING

Parameter	Values
Operating Temperature	From -40 to +85°C
Hail Diameter @ 80km/h	Up to 25mm
Surface Maximum Load Capacity	Up to 5400Pa
Maximum Series Fuse Rating	20A
Application Class and Safety Class	II
Fire Rating (IEC61730)	C
Module Fire Performance (UL 1703)	Type1
Maximum System Voltage	DC 1000V/1500V (IEC/ETL)

PACKING CONFIGURATION

Container	20' GP	40' HQ
Pieces/Container	312	832

- In compliance with our warranty terms and conditions.
- Measurement conditions under irradiance level of Standard Test Conditions(STC): 1000W/m²
Air mass 1.5 Spectrum, cell temperature of 25°C.

ELECTRICAL CHARACTERISTICS

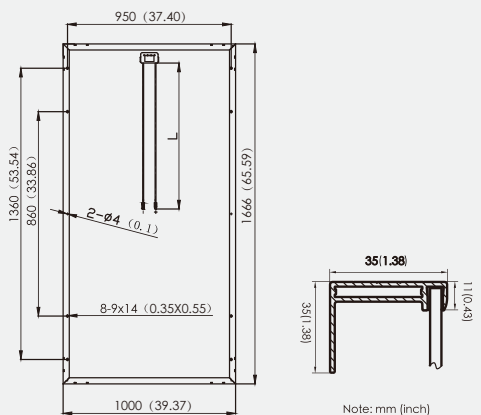
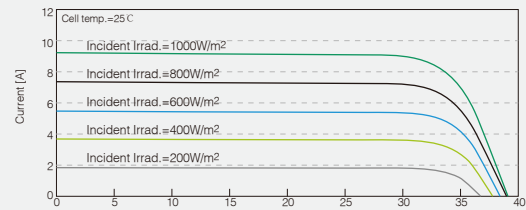
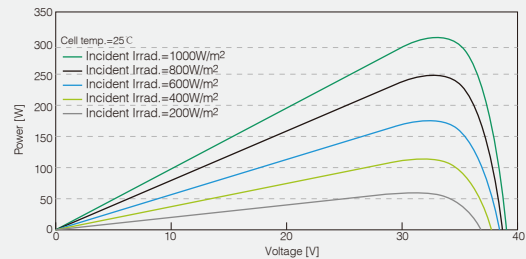

Phono[®] Solar

Note: This datasheet is not legally binding. Phono Solar Technology Co., Ltd. reserves the right to adjust specifications without notice. Further information please refer to our [Website:www.phonosolar.com](http://www.phonosolar.com), [E-mail:info@phonosolar.com](mailto:info@phonosolar.com)